

1. PRECAUTION

Please read through this Manual before using the instrument for correct handling. Please keep this Manual carefully after use. This instrument has been thoroughly tested at the factory before shipment. When you receive it, visually inspect it for damage and check the accessories.

① Model number and specification check
Check to see the model number and specifications on the nameplate at the front of the instrument are as ordered.

② Contents of Instruction Manual
This instruction manual provides instructions on handling, external wiring, and safety use of the instrument.

2. GENERAL

This compact plug-in type PT transmitter receives AC current signal from potential transformer (hereafter called PT) and converts it into isolated DC signal.

Accessories:
Spacer (for DIN rail mounting use) 1
Tag Number Label 2

3. MOUNTING METHOD

JUXTA M-series signal conditioners can be mounted on wall or DIN rail.

3.1 Wall mounting

Unlock stopper and remove main body from the socket as shown in Fig.1. Then fix the socket on the wall with screws. Take installation intervals as shown in Fig. 3. (See Fig. 3 for mounting dimension)

3.2 DIN rail mounting

Insert DIN rail into the upper section of the DIN rail groove on the rear of the socket and fix the rail with slidelock at the base of the instrument as shown in Fig. 2. Use furnished spacer so as to install the instruments with 5mm intervals.

3.3

When use of wiring duct, install it aparting more than 20mm from top of the instrument.

4. EXTERNAL WIRING

CAUTION Wiring should be done after ensuring power break of each cable.

See Fig. 4 for terminal arrangement.

Wiring should be connected to terminals of socket of the transmitter (See Fig. 5). M3.5 screws are used for outer connection. Use round crimp-on terminal for connection to terminal.

4.1 Wiring

- ① Connect input signal cable to 3(V), 4(±) of transmitter.
- ② Connect output signal cable to 1(+), 2(-).
- ③ When DC drive, connect power cable to 7(+), 8(-).
When AC drive, connect power cable to 6(GND), 7(L), 8(N).

NOTE : Apart wiring of power and input/output cables from noise source. Otherwise, accuracy may not be warranted.

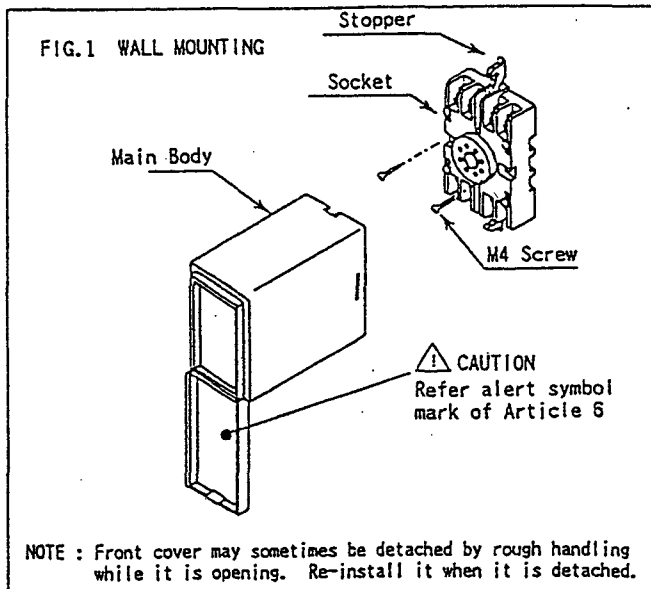

FIG.2 DIN RAIL MOUNTING

When remove instrument from DIN rail, lower the slidelock with (-) screwdriver

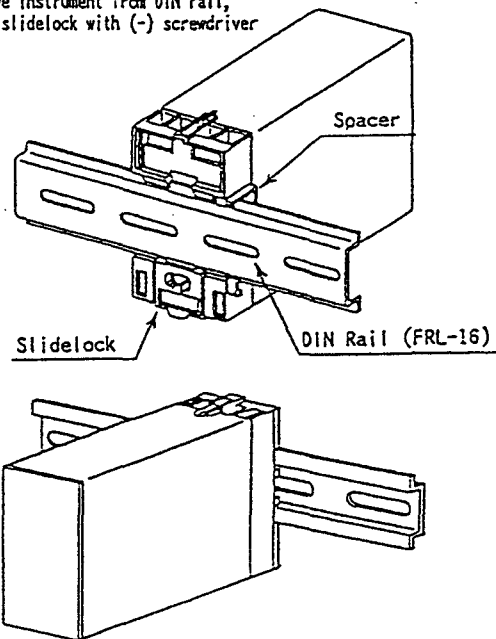
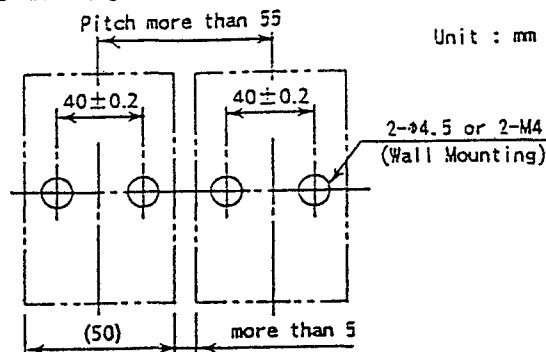

Fig.3 Mounting Dimension



5. INSTALLATION AND HANDLING

- ① Avoid installation in such environments as shock, vibration, corrosive gas, dust, water, oil, solvent, direct sunlight, radiation, powerful electric and magnetic fields.
- ② In order to protect instrument from inducement of thunder surges in power and signal cables by thunder fall, use arrester between the instrument and equipment installed in the field.

6. SAFETY USE

The following caution for safety should be taken for handling of instrument. We are not responsible for damage incurred by use contrary to caution.

CAUTION

- Be sure to lock the stoppers (top and bottom) after mounting the body into socket.
 - The following items should be confirmed when turning power on. Use of instrument by ignoring the specifications may cause over heating or burning.
 - (a) Voltage of power supply and input value be applied to the instrument should meet with required specifications.
 - (b) External wiring to terminals should be connected correctly. (See preceding Article 4)
 - Do not use the instrument in such dangerous places where exist inflammable and explosive gas or steam.
- ⚠ Instruments using power of 85~132V AC/85~150V DC or 170~264V AC have these voltages internally. When opening front cover for zero/span adjustment etc., be careful for electric shock touching by hand or driver the parts other than adjustment trimmer.

7. MAINTENANCE

Carry out the following calibration after warming up the instrument for 10~15 minutes.

7.1 Calibration equipment

- AC Voltage/Current Generator (Yokogawa Model 2558 or equivalent) : 1
- Voltmeter (Yokogawa Model 7551 or equivalent) : 1
- Resistor 250Ω ± 0.01% 1W : 1

7.2 Calibration

- ① Connect equipment as shown in Fig.6.
- ② Input/output characteristics check
Use Voltage/Current Generator and apply input signals equivalent 0, 25, 50, 75, and 100% of input span to the transmitter. Check that the corresponding outputs are 0, 25, 50, 75, and 100% respectively and are within specified accuracy rating range.
Use resistor R for current output only.
- If output signal is out of specified tolerance, adjust it with span and zero adjustment trimmer on front of the instrument.

Fig. 4 Terminal Arrangement

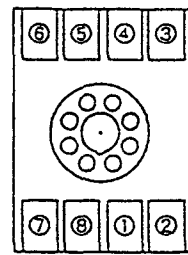

Terminal	
1	OUTPUT (+)
2	OUTPUT (-)
3	INPUT (V)
4	INPUT (I)
5	
6	GND (G)
7	SUPPLY (L+)
8	SUPPLY (N-)

Fig. 5 Wiring Diagram

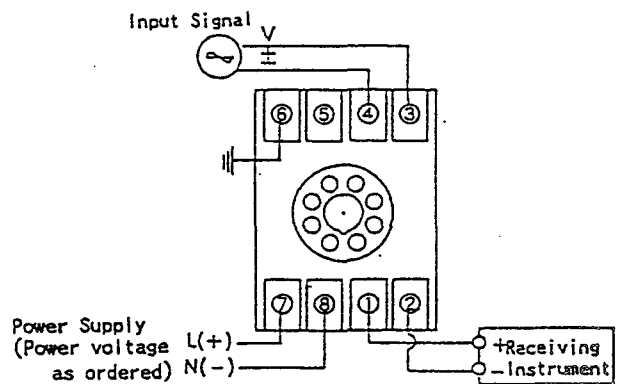
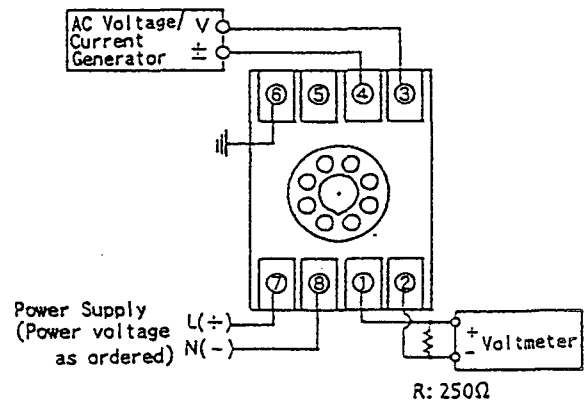

Fig. 6 Wiring of Calibration Equipment



Subject to change without notice for grade up quality and performance.